

20 Series

Model 20-02-06 Adhesive Supply Servo Pump

Simplify your pumping needs.

vanSCO's Model 20-02-06 Adhesive Supply Servo Pump allows excessive adhesive pressure to self-release back into the pump on shutdown for dynamic pressure relief. This design also offers a push fitting conveniently located at the air inlet for an easy installation. An advanced design improves your system's overall efficiency.

vanSCO's 20-02-06 Adhesive Supply Servo Pump:

Speed Compensating Pressure Control

Adhesive pressure will track both up and down with a change in line speed.

Constant Pressure Supply

An all-pneumatic design delivers a continuous and consistent supply of pressure for your adhesive directly from a pail, drum, or tote.

Designed for Durability

A flexible, relaxed diaphragm seal located between fluid and air sections, eliminates packing or sliding seals that would otherwise wear, leak, adjust, or jam.

Pumps On Demand

Will not run continuously unless material is being dispensed.

Filter Elements

Stainless-steel filter elements available in 16, 30, 50, and 100 mesh.

Corrosion Resistant

All components of fluid section are stainless-steel, nylon, Teflon®, or UHMW polyethylene.

Fully Adjustable

Regulated control allows pressure variation between zero and 60 psi.



How to order:

Part Number	Description
20-02-06	Adhesive Servo Pump
95-08-86	Servo cable, PS2, 20 ft
95-08-87	Servo cable, PSMT, 15 ft

Recommended Parts:

78-00-56	Inlet kit, pail or drum mount
78-00-57	Inlet kit, wall mount
90-07-26	3/8" OD tube outlet push fitting
90-00-95	3/8" OD fluid outlet tube
90-03-12	Strainer element, SS, 50 mesh
90-03-13	Strainer element, SS, 100 mesh
90-03-14	Strainer element, SS, 16 mesh
90-03-16	Strainer element, SS, 30 mesh

(The pump does not ship with a strainer element)

System Layout

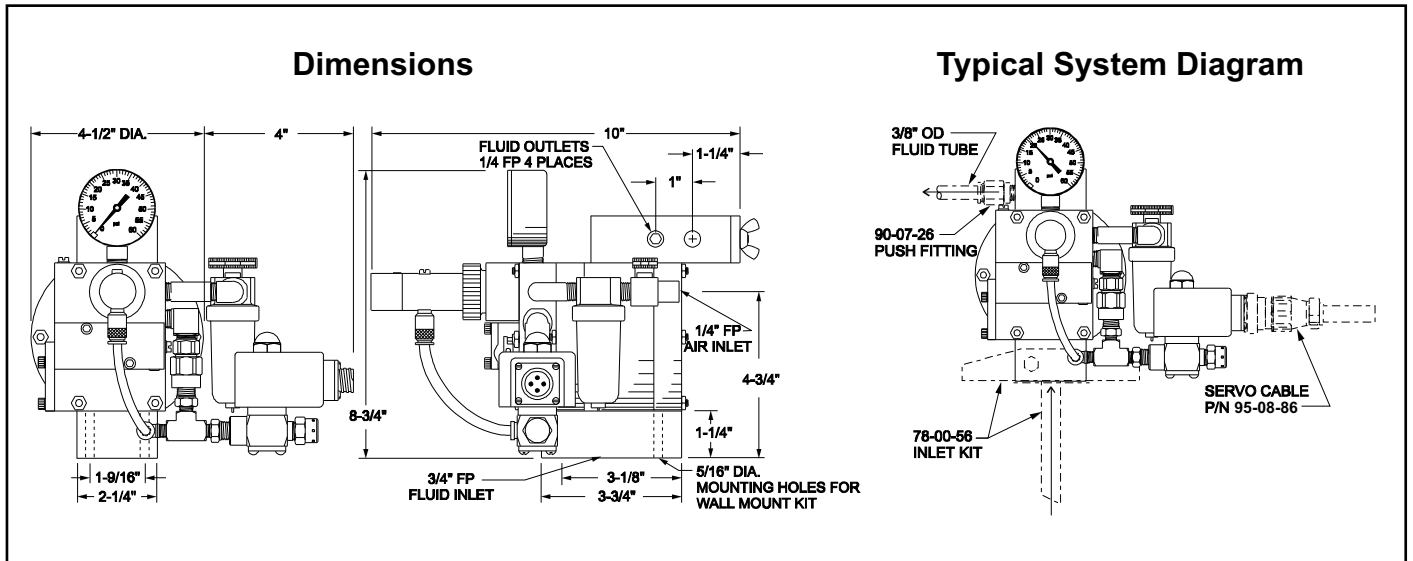

Technical Characteristics

Adhesive Supply Servo Pump Specifications	
Inlet air pressure:	70-120 psi filtered, regulated, and lubricated compressed air
Maximum continuous pumping rate:	25 gallons per hour with 1,000 cps viscosity adhesive
Maximum output pressure:	60 psi
Cycles per gallon:	60
Air consumption:	3.5 cubic feet per gallon under average conditions
Input signal voltage:	0-20 VDC (0.3 amps maximum)
Construction:	All wetted parts are stainless-steel, nylon, Teflon, or UHMW polyethylene
Maximum adhesive viscosity:	6,000 cps with 3 ft x 3/4" diameter suction tube, drum or pail mount kit 2,000 cps with 9 ft x 3/4" diameter suction tube, wall mount kit

For more information visit www.vansco.com or contact us direct.



VanSco Products
 2652 Lashbrook Avenue, South El Monte, CA 91733
 Tel: 626.448.7611 / Fax: 626.448.0221
sales@vansco.com
www.vansco.com



20-02-06

SERVO PUMP COMPONENT PARTS

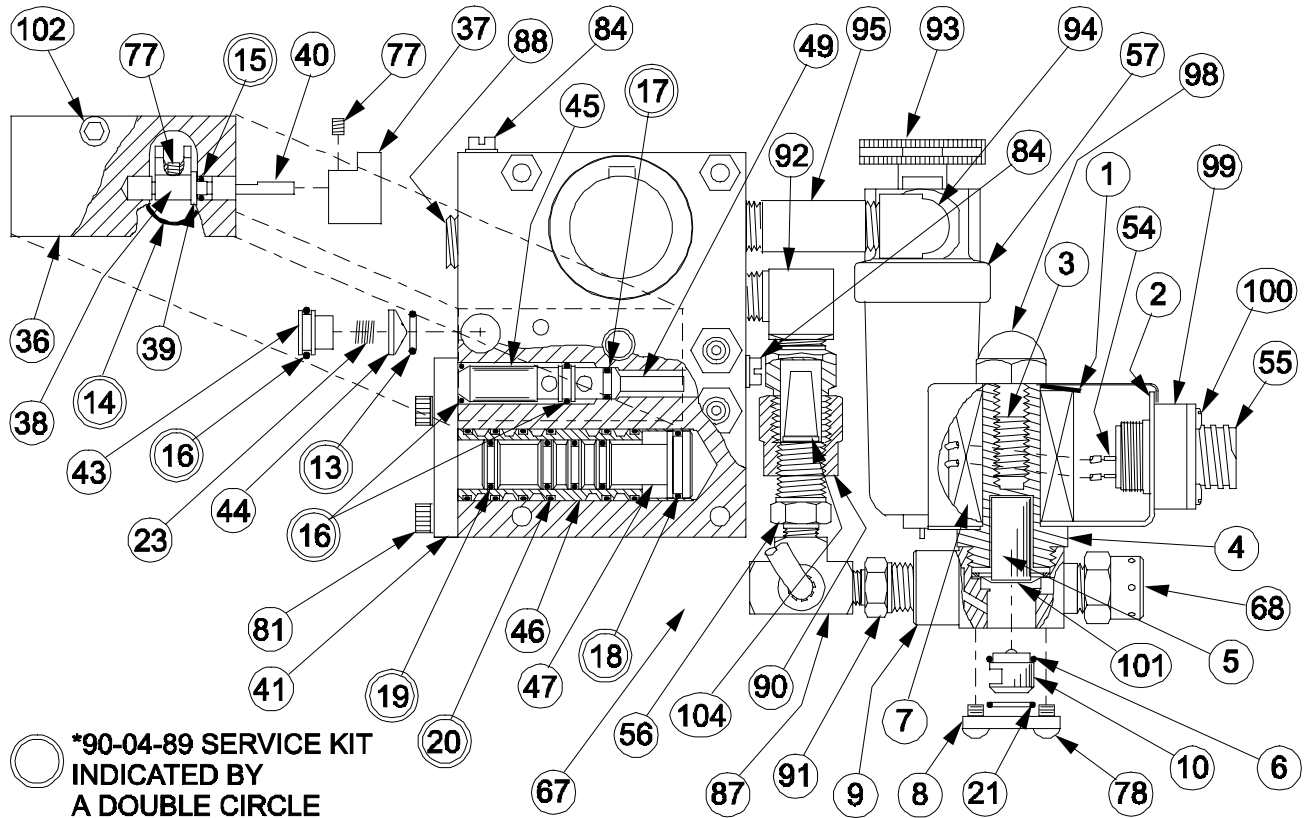

ITEM	PART NO.	QTY	DESCRIPTION
1	90-40-49	1	Spring Washer
2	90-20-76	1	Coil Cover & Mounting Bracket
3	90-20-72	1	Pressure Zero Screw
4	90-20-71	1	Armature Tube
5	90-20-70	1	Armature
6	90-40-42	1	Gasket
7	90-40-44	1	Coil
8	91-79-40	1	Base Plate
9	90-40-20	1	Valve Body
10	90-20-69	1	Seat & Ball Assembly
*13	90-02-36	2	O-Ring
*14	90-00-42	1	O-Ring
15	See over for part number and description.		
*16	90-06-33	3	O-Ring
17	See over for part number and description.		
*18	90-02-32	1	O-Ring
*19	90-05-23	4	O-Ring
*20	90-02-58	6	O-Ring
21	90-02-61	1	O-Ring
23	91-20-15	1	Spring
36	90-20-99	1	Rocker Housing
37	90-20-98	1	Rocker
38	90-20-97	1	Fork
39	90-20-96	1	Rocker Shaft Seal
40	90-20-95	1	Rocker Shaft
41	90-20-94	1	Valve End Plate
43	90-20-92	1	Poppet Stop
44	90-20-91	1	Check Valve Poppet

ITEM	PART NO.	QTY	DESCRIPTION
45	90-20-90	1	Spacer
46	90-20-89	1	Main Valve Sleeve
47	90-20-88	1	Main Valve Spool
49	90-20-81	1	Ejector
54	95-06-23	2	Barrel Pin
55	95-06-14	1	4-Pin Circular Receptacle
56	91-20-45	1	Restrictor Assembly
57	90-06-94	1	Mini Air Line Filter
67	90-07-41	1	1/8"MP x 1/4"OD Push Fitting
68	90-20-73	1	Vent Cap
77	90-06-57	2	8-32 x 3/16" SOHD Set Screw
78	90-05-52	4	8-32 x 3/8" RH Machine Screw
81	90-06-59	2	10-32 x 1/2" SOHD Cap Screw
84	See over for part number and description.		
87	90-05-43	1	1/8"FP Tee Connector
88	See over for part number and description.		
90	90-06-92	1	1/4"MP x 1/4"FP Filter Assembly
91	90-01-84	1	1/4"MP x 1/8"MP Adapter
92	90-02-00	1	1/4"MP x 1/4"FP 90° Elbow
93	90-00-28	1	1/4"MP x 1/4"FP Air Valve
94	90-03-96	1	1/4"MP x 1/4"FP 90° Elbow
95	90-06-95	1	1/4"MP x 1-1/2" Nipple
98	90-06-43	1	1/2-20 Cap Nut
99	95-06-59	1	Spacer
100	90-06-88	4	4-40 x 5/8" Machine Screw
101	91-20-39	1	Diaphragm
102	90-05-63	2	10-32 x 1" SOHD Screw
104	90-03-68	1	Filter Element

See over

VanSco Products - The Gluing Equipment Innovators

2652 Lashbrook Avenue • South El Monte, CA 91733 • 626-448-7611 • Fax 626-448-0221
www.vansco.com • sales@vansco.com



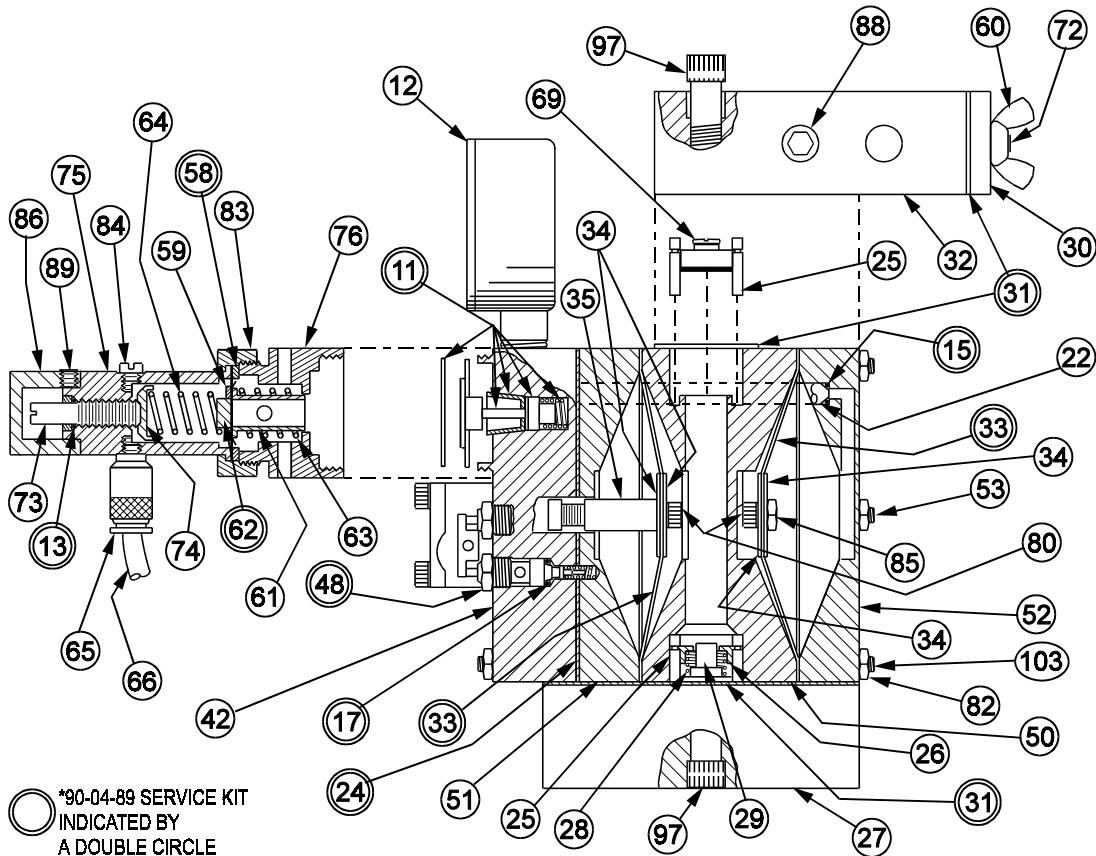

ITEM	PART NO.	QTY	DESCRIPTION
*11	90-04-44	1	Air Regulator Kit
12	90-00-20	1	0-60 psi Air Pressure Gauge
*13	90-02-36	2	O-Ring
*15	90-02-67	3	O-Ring
*17	90-06-55	3	O-Ring
22	91-20-16	1	Cross-Over Tube
*24	91-20-14	1	Gasket
25	91-20-42	2	Poppet Guide (set of three)
26	91-20-12	1	Poppet Stop
27	91-20-54	1	Check Valve Cap
28	91-20-10	1	Spring
29	91-20-09	1	Check Valve Poppet
30	91-20-08	1	End Cap
*31	91-20-07	3	Gasket
32	91-20-06	1	Strainer Body
*33	91-20-05	2	Diaphragm
34	91-20-04	4	Diaphragm Plate
35	91-20-00	1	Actuating Rod Assembly
42	91-20-44	1	Air Manifold
*48	90-20-84	2	Pilot Valve Assembly
50	90-20-80	1	Pump Body
51	90-20-79	1	Pumping Chamber Cover
52	90-20-78	1	Accumulator Cover
53	91-20-40	2	10-32 x 3-11/16" Threaded Stud

ITEM	PART NO.	QTY	DESCRIPTION
*58	91-20-36	1	1" ID Nylon Washer
59	90-82-24	1	Nylon Washer
60	90-07-57	2	1/4-20 Wing Nut
61	91-20-24	1	Diaphragm Spacer
*62	91-20-35	1	Diaphragm
63	90-82-02	1	Spring
64	90-82-37	1	Spring
65	90-07-37	1	10-32 x 3/8" OD Tube Push Fitting
66	90-00-49	6"	1/4" OD Poly Tube
69	91-20-48	1	Check Valve Poppet Assembly
72	90-07-56	2	1/4-20 x 1" SOHD Set Screw
73	91-20-31	1	Zero Adjust Screw
74	91-20-27	1	Spring Button
75	91-20-29	1	Pilot Housing
76	91-20-28	1	Vent Chamber
80	90-05-59	2	10-32 x 1/4" SOHD Cap Screw
82	90-06-08	12	10-32 Hex Nut
83	91-20-51	1	Lock Ring
84	90-46-29	4	10-32 Plug with Gasket
85	90-01-11	1	10-32 Hex Nut
86	91-20-49	1	Adjustment Cover
88	90-03-87	4	1/4"MP SOHD Plug
89	90-05-39	1	8-32 x 3/16" Set Screw
97	90-06-58	4	5/16-18 x 1-3/4" SOHD Cap Screw
103	91-20-41	4	10-32 x 4-3/4" Threaded Stud

Distibuted By:

*Pump Service Kit 90-04-89
Contains:11, 13, 14, 15, 16, 17, 18, 19, 20, 24, 31, 33, 48, 58, 62

CBV0500

20-02 SERIES PRINCIPLES OF OPERATION

ADHESIVE SUPPLY PUMP

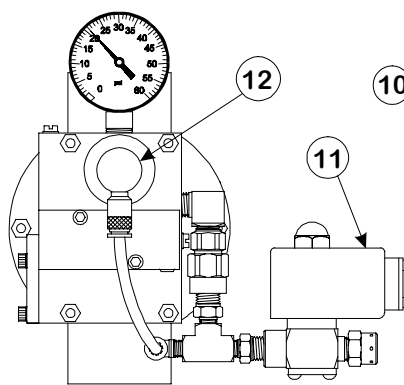

SERVO PUMP

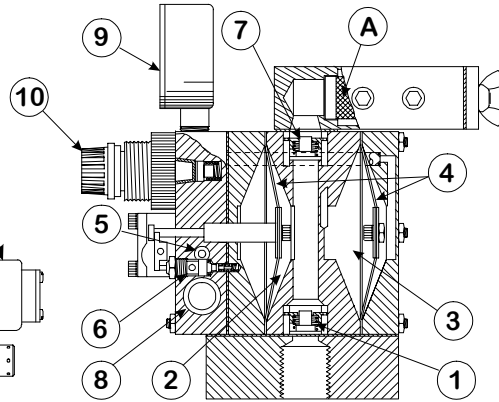

MANUAL PUMP

- 1 Inlet Check Valve
- 2 Primary Pumping Chamber
- 3 Secondary Pumping Chamber
- 4 Diaphragm
- 5 Vacuum Ejector
- 6 Pilot Valve
- 7 Outlet Check Valve
- 8 Directional Air Valve
- 9 Pressure Gauge
- 10 Pressure Adjustment Knob (Manual pump only)
- 11 Servo Regulator (Servo pump only)
- 12 Air Regulator (Servo pump only)
- A Strainer Element

The 20-02 series pump supplies an adjustable amount of constant, unvarying pressurized adhesive. The pump is a pneumatically operated, floating diaphragm, single acting, on demand, 1:1 pressure ratio pump. The adhesive section of the pump (#2 and #3) is separated from the pneumatic section by two floating, unstressed diaphragms (#4). The primary pumping chamber (#2) is combined with a secondary pumping chamber (#3) that supplies flow during the pump suction stroke.

During the suction stroke, an internally created vacuum draws fluid through the inlet check valve (#1) into the primary pumping chamber (#2). When the pumping chamber is full, the lower pilot valve (#6) shifts a directional air valve and applies regulated air pressure to the primary pumping chamber. This blocks the inlet check valve and forces adhesive through the outlet check valve (#7) at a pressure equal to the amount shown on the pump gauge (#9).

During the delivery stroke, the primary pumping chamber (#2) supplies output flow and fills the secondary pumping chamber (#3). When the primary pumping chamber (#2) is empty, the directional air valve (#8) is shifted back to its original position by the upper pilot valve (#6). As a result, regulated air pressure is applied to the secondary pumping chamber (#3) and the vacuum ejector (#5) is turned on, initiating a new suction stroke.

Adjusting the knob (#10) located on the front of the pump varies the output pressure on the manually adjustable pump (20-02-00, 20-02-01).

Adjusting the fluid volume control on the connected controller varies the amount of voltage supplied to the proportional air valve (#11) and varies the output pressure on the servo-controlled pump (20-02-05, 20-02-06). This in turn backs up pilot air pressure that opens the pump (#12) a measured amount. The greater the voltage, the higher the adhesive output pressure.

TECHNICAL INFORMATION

ADHESIVE SUPPLY REQUIREMENTS:

Adhesive Supply Pressure:

No adhesive pressure required at the pump inlet.

Adhesive Filtration Requirement:

50-mesh strainer

Adhesive Viscosity Recommendations:

6000 cps with 3 foot suction tube

2000 cps with 9 foot suction tube

Adhesive Composition Requirements:

All wetted parts are stainless steel, nylon, Teflon, and UHMW polyethylene, so any material that is compatible with these materials is acceptable.

PNEUMATIC SUPPLY REQUIREMENT

Operating air pressure: 70 to 120 psi filtered, regulated, and lubricated

Air consumption

Maximum: 3.0 cubic feet per minute

Typical: 0.4 cubic feet per minute,
3.5 per gallon of adhesive delivered

ELECTRICAL SUPPLY REQUIREMENTS:

(servo pump only)

0 to 20 VDC (0 to 0.25 amps)

OUTPUT RESULTS:

Maximum output pressure:

Manual pump: 100 psi

Servo pump: 60 psi

Maximum flow: 25 gallons per hour with 1,000 cps adhesive

MOUNTING REQUIREMENTS:

Fluid inlet: 3/4" FNPT

Air inlet: 1/4" FNPT

Electrical inlet: (servo pump only) 4-pin circular electrical connector

General Mounting:

The **manual pump** can be mounted in any position without effecting function.

The **servo pump** must be mounted so that the proportional air valve is in an upright position at all times.

FLUID OUTPUT ADJUSTMENT:

Manual pump 20-02-00 and 20-02-01:

The fluid output pressure is adjusted by rotation of the knob located on the front of the pump.

Servo pump 20-02-05 and 20-02-06:

The fluid output pressure is adjusted by varying the amount of voltage that is supplied to the proportional air valve. The higher the voltage the higher the output pressure. This can be accomplished by using one of VanSco's variable speed controllers.

MAINTENANCE

INITIAL START UP, RUNNING PRODUCTION, SHUTDOWN, AND RESTART:

Start up:

1. The inlet suction tube must be shorter than the depth of the pail or drum of adhesive. Shorten the suction tube to a length that just reaches the bottom of the adhesive container without restricting flow. Use a hacksaw for best results. Install fluid inlet suction tube at bottom inlet on the pump. Make certain not to cross thread suction tube. Install the suction tube gasket seal against base of pump.
2. Purge all fluid and air lines of foreign material prior to running production. It is recommended to purge the air line with clean, dry, unlubricated air.
3. With the inlet air pressure OFF, install pump in desired location and connect air inlet line and servo cable (servo pump only).
4. Install output adhesive lines to the outlet ports in the strainer block housing (top of pump). Make sure all adhesive fittings are secure. Turn on the air pressure to the pump. The pump will begin to cycle quickly until fluid fills the entire pump. From this point on, the only pump cycling will occur when the output demand requires it. Check all adhesive applicator lines for leaks.

<p>If the pump does not self-prime, priming of the pump can be achieved by turning the pump upside down and filling the fluid inlet suction tube with adhesive prior to inserting the tube in to the adhesive supply container.</p>

Running Production:

Adjust the pump outlet pressure to the desired setting. The typical application pressure is between 20 and 30 psi. Start at about 20 psi for the initial start up and adjust it up or down as needed. Push in the red lock ring on the adjustment knob to lock the pressure at the desired setting (manual pump only).

Shutdown:

It is not necessary to flush the system of adhesive during any shutdown period less than thirty days. Flushing the system is recommended for shutdowns exceeding 30 days.

Check Lists:

Monthly:

1. Check strainer element and remove any debris that may have collected. Strainer element is located in the four-outlet strainer body.
2. Check for air bubbles in the adhesive supply.
3. Check for constant exhaust from the pilot valve exhaust hole.

TROUBLESHOOTING GUIDE:

Problem:	Cause:	Solution:
Pump cycles rapidly with little or no output	Pump is not primed	Prime pump by turning pump upside down and filling suction tube with adhesive
	Suction tube does not reach adhesive in barrel	Replenish adhesive supply
	Outlet check valve jammed open	Remove debris from outlet check valve
	Suction tube incorrectly installed	Air in sucked in around threads. Re-install suction tube correctly
	Inlet check valve block loose	Tighten inlet check valve block
Pump cycles rapidly but continues to supply adhesive	Defective lower pilot valve	Replace lower pilot valve
	Valve spool or sleeve O-ring leak	Replace all valve spool and sleeve O-rings
Pump does not cycle or no adhesive at outlet	Clogged strainer element	Remove debris from strainer element
	Dry valve spool O-rings	Lubricate spool O-rings and check inlet air lubricator
	Loose rocker or fork set screw	Tighten set screws in fork and rocker
	Clogged suction tube	Remove debris from suction tube
Pump rapidly cycles when no adhesive is being dispensed	Defective pilot valve	Replace both pilot valves
	Valve spool or sleeve O-ring leak	Replace all spool and sleeve O-rings
	Inlet check valve jammed open	Remove debris from inlet check valve
Long or continuous valve spool exhaust	Defective upper pilot valve	Replace upper pilot valve
	Valve spool or sleeve O-ring leak	Replace all spool and sleeve O-rings
Short valve spool exhaust	Defective lower pilot valve	Replace lower pilot valve
Constant pilot valve exhaust	Defective lower pilot valve	Replace lower pilot valve
Maximum output pressure not attainable	Valve spool or sleeve O-ring leak	Replace all spool and sleeve O-rings
	Insufficient inlet air pressure	Inlet air pressure must exceed desired outlet pressure by 10 psi minimum
	Pilot section leak (servo pump only)	Check entire pilot section for leaks
	Debris in proportional air valve ball & seat (servo pump only)	Repair proportional air valve
	Insufficient electrical input signal (servo pump only)	Check controller input signal
Adhesive in air section of pump	Loose actuating rod assembly	Tighten actuating rod assembly
	Leak in diaphragm	Replace diaphragm
Little or no adhesive pressure regulation (servo pump only)	Proportional air valve malfunction	Repair proportional air valve
	Insufficient electrical input signal	Check controller for proper output signal (See controller manual)

CBP0101

INTERNATIONAL HEADQUARTERS
 2652 Lashbrook Avenue • South El Monte, CA 91733 • 626-448-7611 • Fax 626-448-0221
 Sales and service offices world wide

vanSCO®