

46 Series

Air Mizer, Anti-Flood Assembly

Completely pneumatic.

vanSCO's pneumatic and efficient **Air Mizer** system cuts out 70% in wasted constant air by maintaining total regulation of the atomizing air supply. The atomized air supply can be altered because of a delayed shut-off that flushes excess fluid from the nozzle. The VanSCO® Air Mizer brings flexibility, easy installation, and a simple solution to support your industry needs.

vanSCO's Air Mizer:

Adjustable

Atomizing air supply is infinitely adjustable; from entirely off to fully open.

Efficient

The Air Mizer's "off" delay is only between zero to three seconds.

Multiple Outlets

Designed to control from one to four valves simultaneously.

Easy Installation

Comes ready to install with push fittings on inlet air lines for an easy setup.

Adaptable

Able to be used in most pneumatic spray systems.

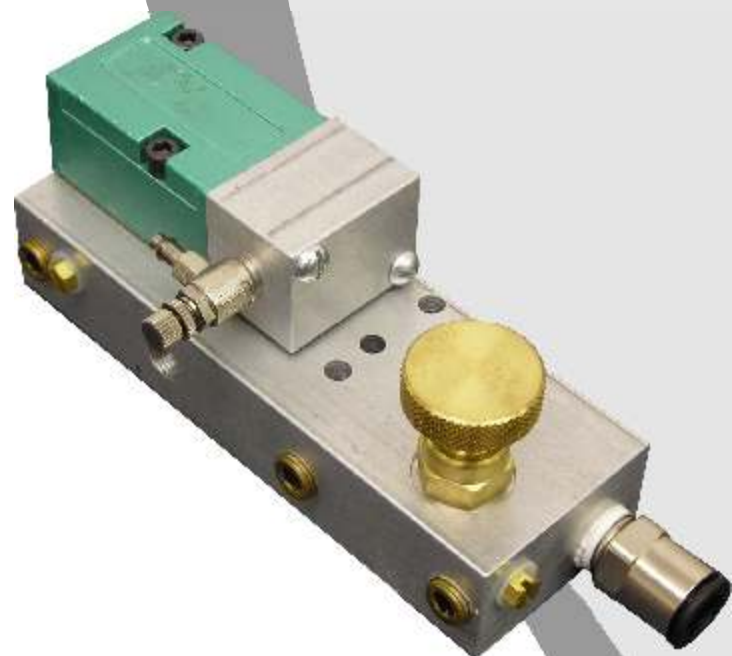

How to Order

Part No.	Description
----------	-------------

46-03-11	Air Mizer
----------	-----------

Recommended Parts

90-00-41	3/8 in. OD poly air tube
90-00-69	1/4 in. OD poly air tubing
90-07-41	1/4 in. OD tube x 1/8 MP push fitting

Dimensions

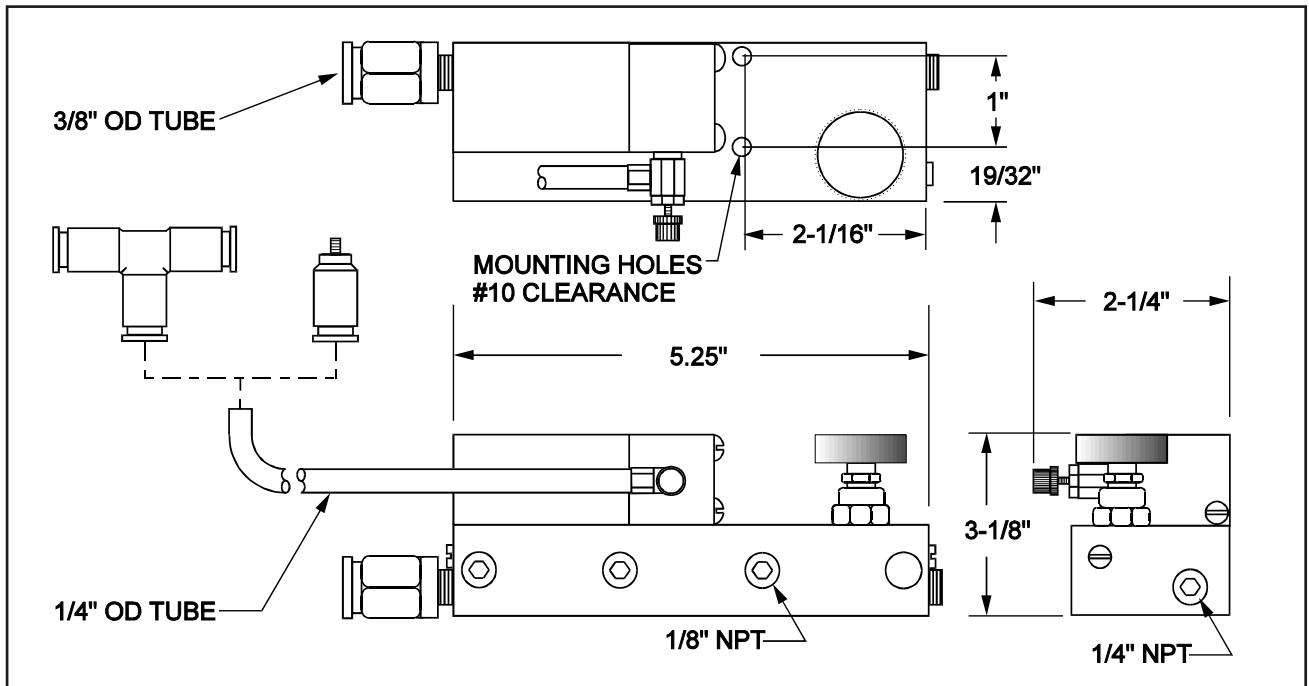

Technical Characteristics

Air Mizer Specifications	
Pilot Air Pressure:	50-125 PSI, filtered and regulated air
Operating Air Capacity:	0-6 cubic feet per minute air supply per outlet port at 80 PSI inlet pressure (maximum inlet pressure 125 PSI)

For more information visit www.vansco.com or contact us direct.



VanSco Products
2652 Lashbrook Avenue, South El Monte, CA 91733
Tel: 626.448.7611 / Fax: 626.448.0221
sales@vansco.com
www.vansco.com



46-03-11

Air Mizer

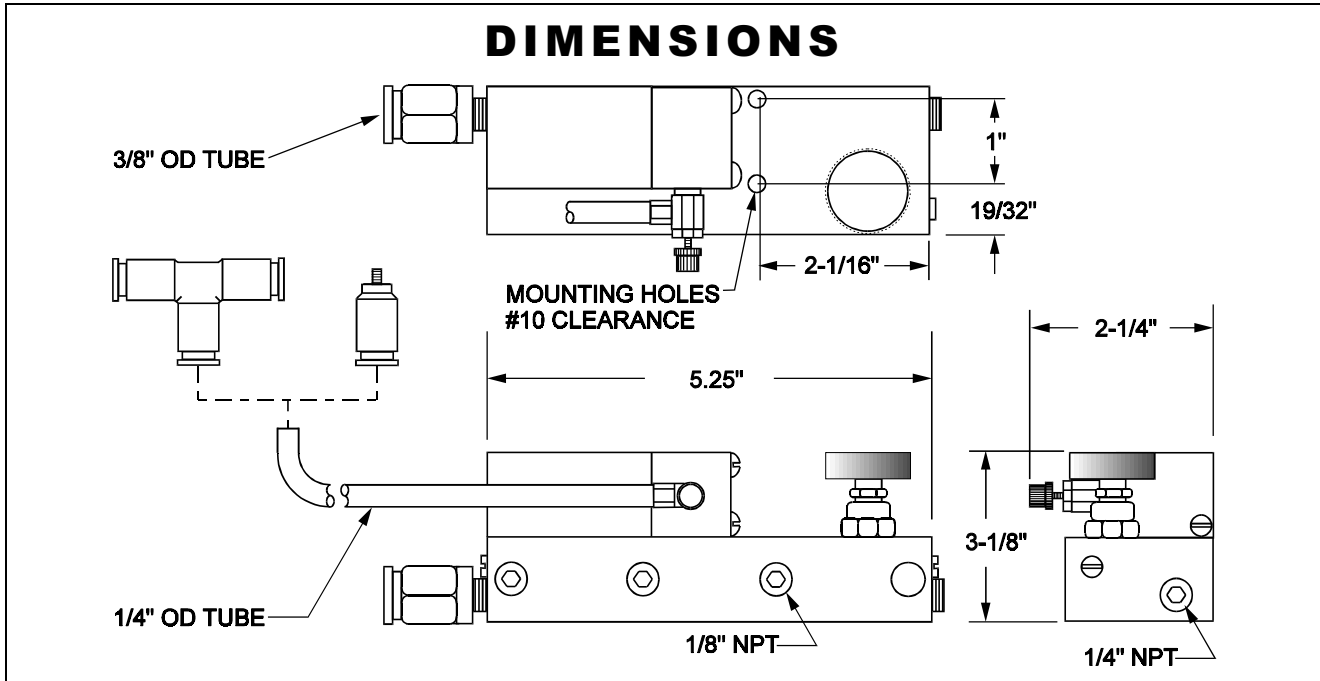

HOW TO ORDER

TECHNICAL DATA

PART NO. DESCRIPTION
46-03-11 Air Mizer

PILOT AIR PRESSURE:
 50 - 125 psi Filtered and Regulated Air.

RECOMMENDED PARTS:
90-00-41 3/8" OD poly air tube
90-00-69 1/4" OD poly air tubing
90-07-41 1/4" OD Tube x 1/8 MP Push Fitting

OPERATING AIR CAPACITY:
 0-6 cubic feet per minute air supply per outlet port at 80 psi inlet pressure. (Maximum inlet pressure 125 psi).

TYPICAL SYSTEM DIAGRAM

Distributed By:

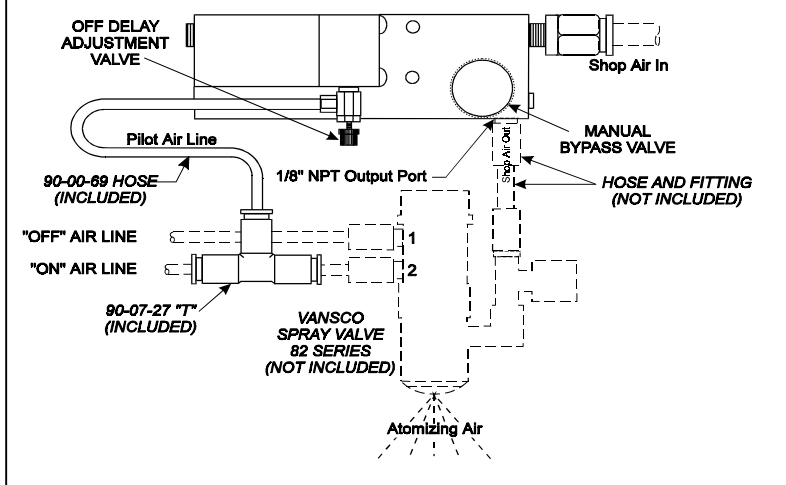

46-03-11 Air Mizer

COMPONENT PARTS

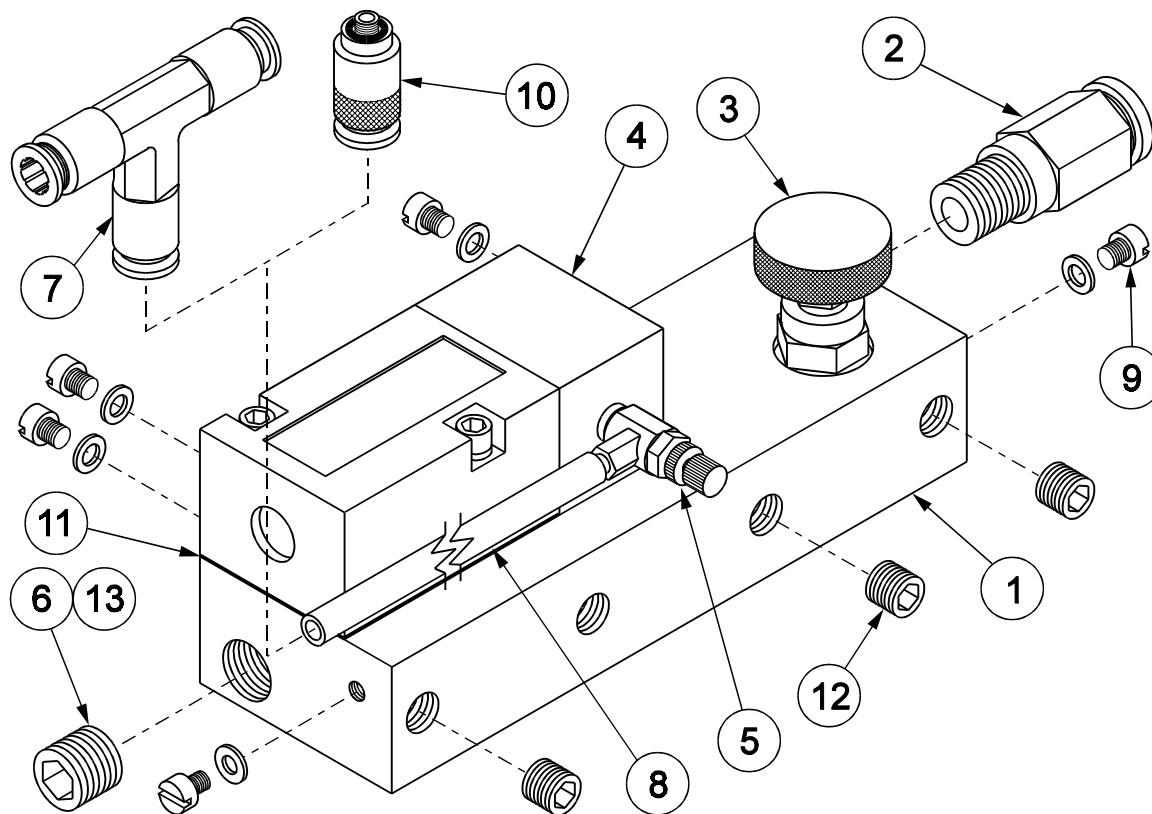

Service Kit

91-04-04 Includes: Detent Body, End Seals, Spring, Spring Retainer, and Gasket

ITEM	QTY	PART NO.	DESCRIPTION
1	1	91-46-21	Manifold Body, 4 Outlet
2	1	90-07-26	3/8 OD Tube X 1/4MP Push Fitting
3	1	90-46-85	Manual Bypass Valve
4	1	91-46-26	Air Pilot 4 Way Spool Valve
5	1	91-46-28	Timing Valve
6	1	90-03-87	1/4" MP Plug, SOHD, SS
7	1	90-07-27	1/4" OD Tube Tee Push Fitting

ITEM	QTY	PART NO.	DESCRIPTION
8	3'	90-00-69	1/4" OD X 11/64 ID Poly(N) Tube
9	5	90-46-29	10-32 Plug with 90-46-28 Gasket
10	1	90-07-37	1/4" OD Tube X 10-32 Push Fitting
11	1	91-41-05	Mounting Gasket
12	3	90-01-91	1/8MP Plug, Hex SOHD, BR
13	1	90-01-81	1/4MP X 1/4MP Adapter (Not Shown)

Distributed by:

VanSco Products-

The Gluing Equipment Innovators
 2652 Lashbrook Avenue • South El Monte, CA 91733 •
 626-448-7611 • Fax 626-448-0221
 E-mail: sales@vansco.com • URL: www.vansco.com

vanSco®