

# 50 & 35 Series

## Trip Gluer Valves & Applicator Heads

### Trouble-free operation.

**vanSCO**'s quality manufactured **Trip Gluer Valves and Applicator Heads** are designed to prevent adhesive buildup for effortless functioning to add value to most any system. Without a need for pneumatic or electrical controls, these components offer a simple system solution.

### **vanSCO**'s Trip Gluer Valves & Applicator Heads features:

#### **Removable Heads**

Tungsten, carbide-coated applicator heads are accessible and easily removed and replaced.

#### **Dependable**

Stainless-steel, spring-returned valve stem assures a reliable shut-off.

#### **Serviceability**

Valve easily detaches from the bracket to be serviced.

#### **Versatile**

Change of pattern width only requires the replacement of the applicator head.

#### **Durable**

Wide contact area of tungsten, carbide-coated tripper increases resilience.



### How to Order

Part No.	Description
50-00-21	Trip gluer with mounting bracket
50-00-25	Trip gluer with mounting bracket and stop plate with quick disconnect
50-00-01	Trip gluer
50-00-05	Trip gluer with stop plate with quick disconnect

# Dimensions

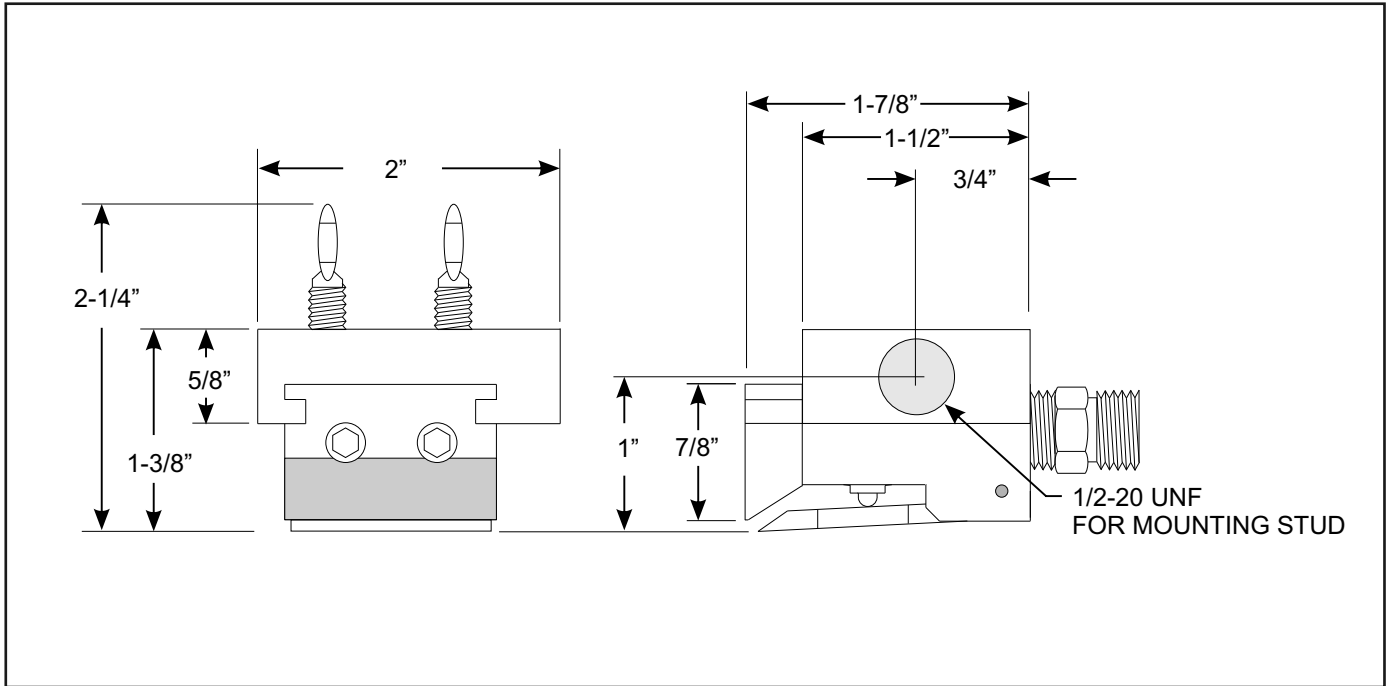

# Technical Characteristics

## Trip Gluer Applicator Head Specifications

<b>Viscosity Range</b> Minimum: 500 Centipoise Maximum: 5000 Centipoise	<b>Options:</b>			
	<b>Part No.</b>	<b>Pattern Width</b>	<b>Vein Diameter</b>	<b>Head Width</b>
<b>Adhesive Pressure Range</b> 0-100 PSI	35-06-01	3/4"	.052"	1-7/16"
	35-08-01	1"	.052"	1-7/16"
<b>Actuating Force</b> Approximately 4 lbs. at tripper tip	35-10-01	1-1/4"	.052"	1-11/16"
	35-14-01	1-1/2"	.052"	1-15/16"
<b>Construction</b> Cold-rolled steel, stainless steel, and aluminum	35-16-01	2"	.040"	2-3/16"
	35-18-01	2-1/4"	.040"	2-11/16"
	35-20-01	2-1/2"	.040"	2-15/16"
	35-22-01	2-3/4"	.040"	3-3/16"
	35-24-01	3"	.040"	3-7/16"

For more information visit [www.vansco.com](http://www.vansco.com) or contact us direct.



**VanSco Products**  
 2652 Lashbrook Avenue, South El Monte, CA 91733  
 Tel: 626.448.7611 / Fax: 626.448.0221  
[sales@vansco.com](mailto:sales@vansco.com)  
[www.vansco.com](http://www.vansco.com)



**50-00-21**  
**50-00-25**

**COMPONENT PARTS**  
**TRIP GLUER & APPLICATOR HEAD**

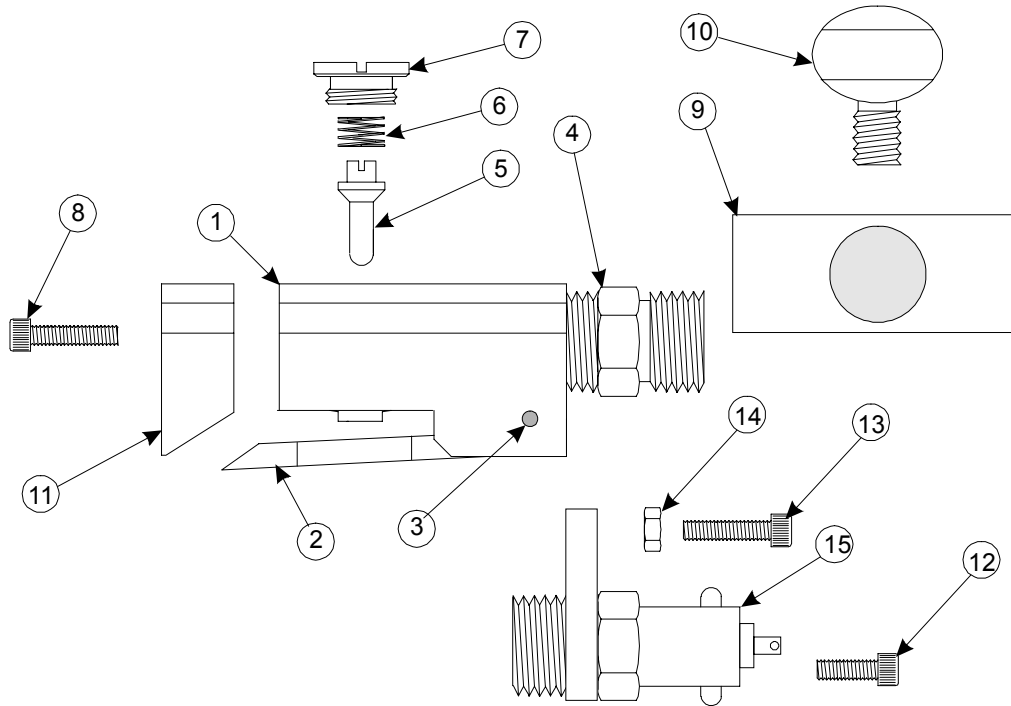

ITEM	QTY	PART NO.	DESCRIPTION
1	1	90-50-21	Valve Body
2	1	90-50-01	Solid Tripper
3	1	90-50-06	Tripper Lock Pin
4	1	90-01-80	1/4" MP X 1/4" MP Adapter, BR
5	1	90-03-58	Valve Stem
6	1	90-03-80	Valve Stem Return Spring
7	1	90-03-77	Valve Stem Retainer Cap
8	2	90-13-18	8-32 X 3/8" SOHD Cap Screw
9	1	90-50-09	Mounting Bracket w/ Thumb Screws
10	2	90-01-96	1/4-20 X 3/4" Thumb Screw
11	See Table		Trip Gluer Applicator Head

Service Kit 90-04-33 consists of items 3, 5, 6, & 7.

**Distributed By:**

ITEM	QTY	PART NO.	DESCRIPTION
<i>Following four items are part of 50-00-25</i>			
12	2	90-13-18	8-32 X 3/8" SOHD Cap Screw
13	1	90-05-62	10-32 X 3/4" SOHD Cap Screw
14	1	90-06-08	10-32 Hex Nut
15	1	90-03-00	1/4 MP Quick Disconnect

**TRIP GLUER APPLICATOR HEAD:**

Part No.	Pattern Width*	Vein Dia.	Head Width
35-06-01	3/4"	.052"	1-7/16"
35-08-01	1"	.052"	1-7/16"
35-10-01	1-1/4"	.052"	1-11/16"
35-12-01	1-1/2"	.052"	1-15/16"
35-14-01	1-3/4"	.040"	2-3/16"
35-16-01	2"	.040"	2-7/16"
35-18-01	2-1/4"	.040"	2-11/16"
35-20-01	2-1/2"	.040"	2-15/16"
35-22-01	2-3/4"	.040"	3-3/16"
35-24-01	3"	.040"	3-7/16"

EAS0800