

60 Series

Model 60-02 Featherweight Hand Valve

Simple, lightweight and durable.

vanSCO's 60-02 Featherweight Hand Valve offers a unique design created with a stainless-steel valve plunger for added durability and long lasting production. A Teflon® valve seat maximizes the quality of the sealing area for optimized efficiency. Its simple design is constructed with a brass push fitting conveniently located at its adhesive inlet for an even easier installation. The Featherweight Hand Valve is perfect for a range of gluing industry application systems.

vanSCO's Featherweight Hand Valve:

Manual Actuation

A thumb force of less than three pounds completely opens the hand valve outlet.

Lightweight

Black nylon construction of major components lightens hand valve weight to minimize operator fatigue.

Designed for Durability

Unique diaphragm seal eliminates packing or sliding seals that typically wear out, leak, adjust, or jam.

Corrosion Resistance

All adhesive section components are stainless-steel, nylon, Teflon®, or UHMW polyethylene.

Brass Inlet Swivel

Valve offers a brass inlet swivel that rotates 360 degrees and maintains perfect function.

VanSCO Components

Can be used with a variety of VanSCO applicator heads.



How to order:

Part Number	Description
60-02-21	Adhesive valve RX connector
60-02-23	Adhesive valve 1/4" FP
33-71-00	Plastic tip adapter, 1/4" MP
90-33-00	Disposable plastic tips (dozen)
90-02-96	Snap connector kit, 1/4" MP
90-00-95	3/8" OD Poly fluid hose

60 Series

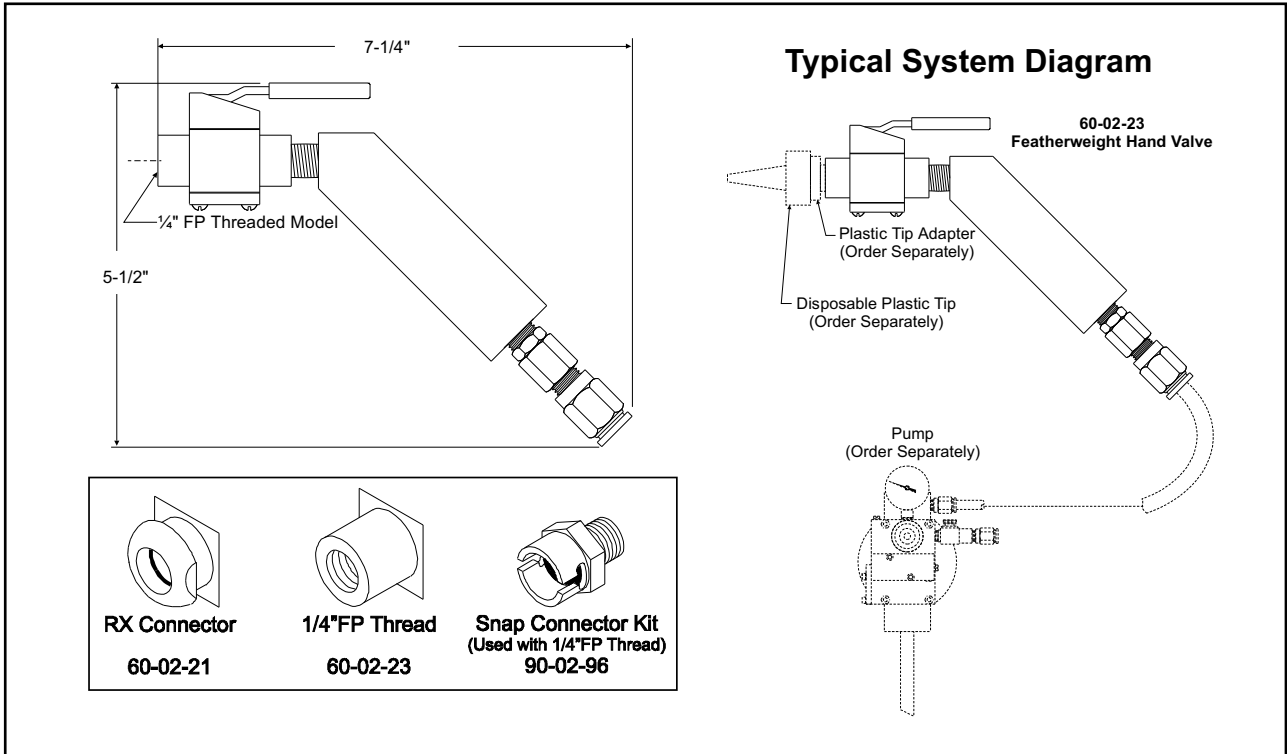

Technical Characteristics

Model 60-02 Specifications		
	Fluid pressure:	1-30 psi
	Fluid viscosity range:	1-20,000 centipoise
	Release Pressure:	2.5 pounds at 80 psi inlet fluid pressure
	Release pressure: Construction:	All wetted parts in adhesive section assemblies consist of stainless-steel, UHMW polyethylene, nylon, and Teflon. Brass inlet swivel and push fitting included.

For more information visit www.vansco.com or contact us direct.



VanSco Products
2652 Lashbrook Avenue, South El Monte, CA 91733
Tel: 626.448.7611 / Fax: 626.448.0221
sales@vansco.com
www.vansco.com



60-02-21 & 60-02-23 Featherweight Hand Valve

COMPONENT PARTS

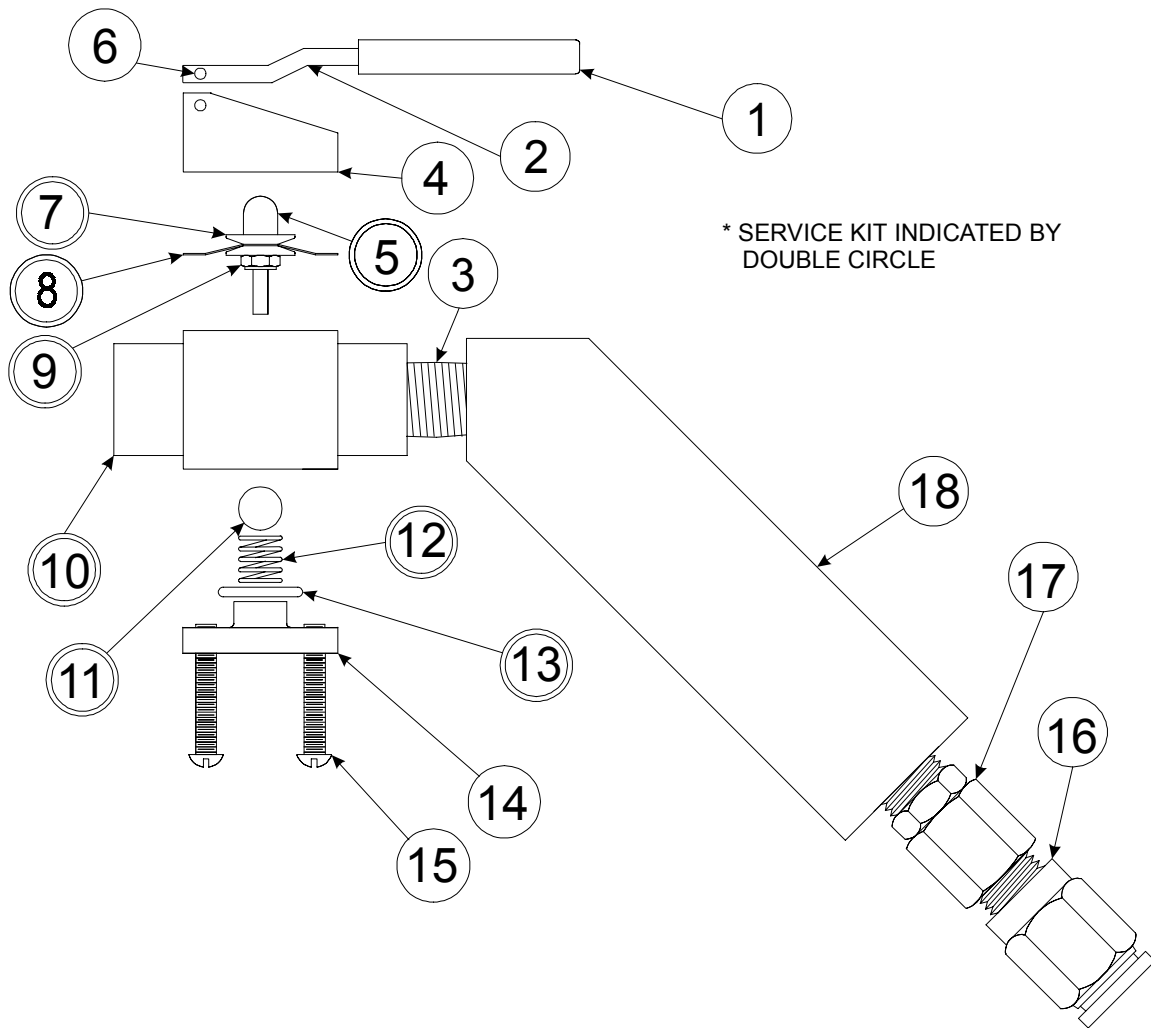

ITEM	QTY	PART NO.	DESCRIPTION
1	1	90-60-32	Lever Cover
2	1	90-60-36	Thumb Lever
3	1	90-07-62	1/4MP Close Nipple, Stainless Steel
4	1	90-60-40	Plunger Cap
*5	1	90-60-42	Plunger
6	1	90-60-35	Pivot Pin
*7	2	90-47-76	Diaphragm Plate
*8	1	90-47-28	Diaphragm
*9	1	90-02-43	4-40 Self Locking Hex Nut, S.S.
*10A	1	90-60-51	Valve Body, Nylon, RX
*10B	1	90-60-53	Valve Body, Nylon, 1/4"FP
*11	1	90-60-38	5/16" Dia. Stainless Steel Ball
*12	1	90-60-41	Return Spring
*13	1	90-02-27	Teflon O-Ring

ITEM	QTY	PART NO.	DESCRIPTION
14	1	90-60-33	Spring Cap, Nylon
15	4	90-03-52	6-32 x 1-3/8" ROHD Screw
16	1	90-07-26	3/8" OD Tube x 1/4" MP Push Fitting
17	1	90-02-04	1/4" MP x 1/4" FP Swivel Connector
18	1	90-60-37	Handle, Nylon

*SERVICE KIT

For 60-02-21 use Service Kit 91-04-25.
For 60-02-23 use Service Kit 91-04-27.

91-04-25 Includes Items: 5,7,8,9,10A,11,12, and 13
91-04-27 Includes Items: 5,7,8,9,10B,11,12, and 13

Distributed By:

EAQ0798