

71-00-10 Flexo-Folder-Gluer Glue Station

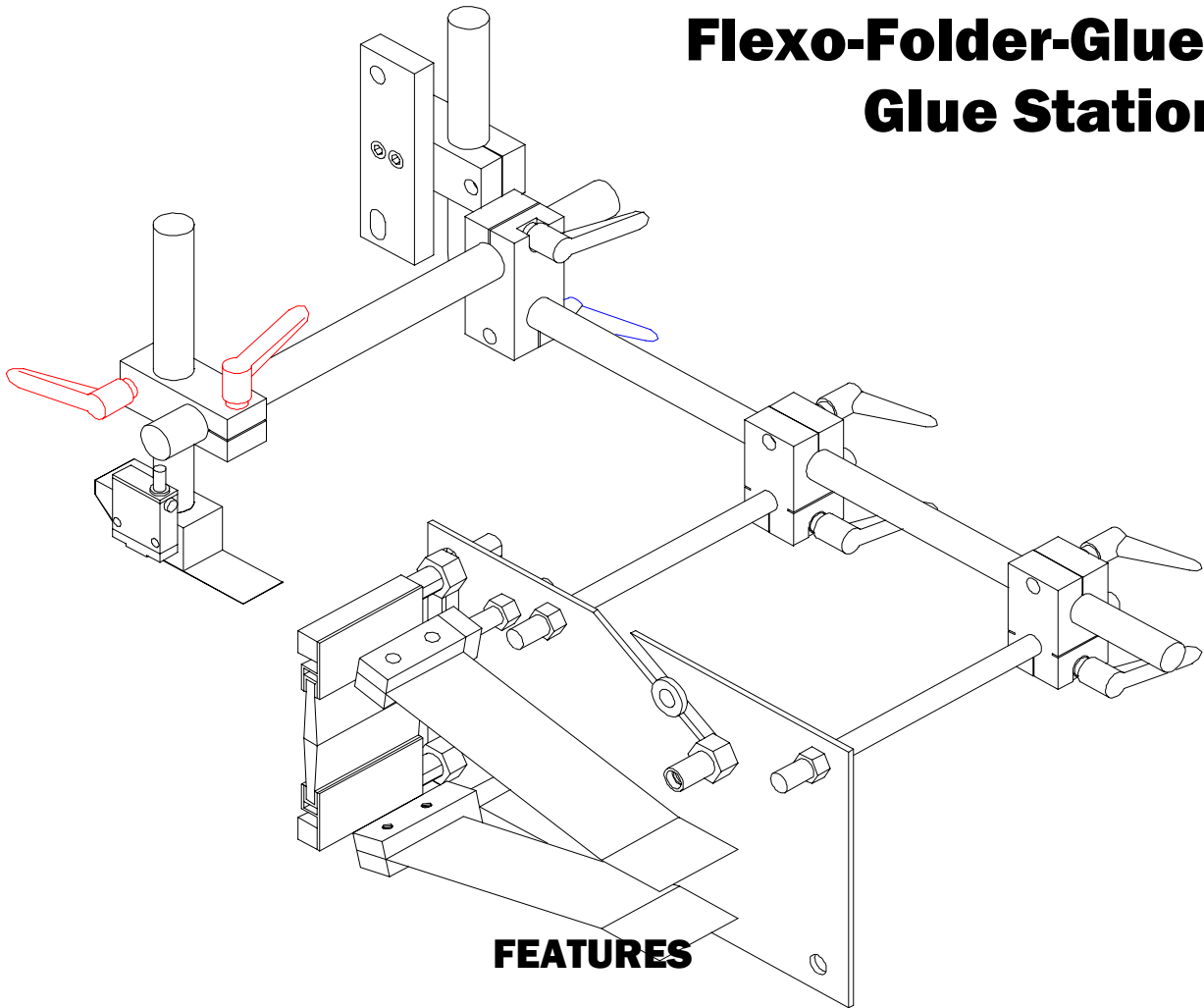

Photo Sensor Bracket – Equipped with a fully adjustable photo sensor bracket with spring steel lead-in guide.

Tab Removal Brushes – Brass tab removal brushes to reduce static electricity and removal of unwanted tabs.

Full Adjustments – Horizontal, vertical, and lateral adjustments with quick release locking handles.

Quick Changes – Valves and applicator heads can be easily removed from the bracket by loosening two nuts.

Adjustable Spring Steel Guides – for both top and bottom applications.

Versatile – Glue station can be moved easily from left to right side of machine by simply mounting components on the opposite side of main station plate.

71-00-10

Glue Station

GLUE STATION WITH ADHESIVE VALVE AND PHOTO SENSOR

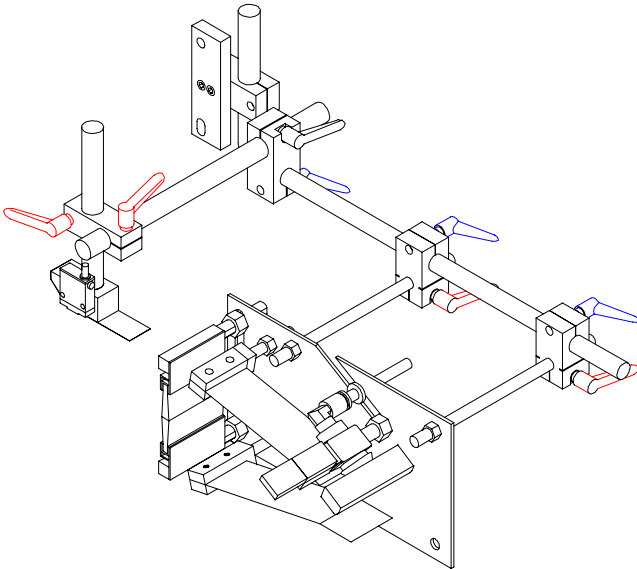

HOW TO ORDER

GLUING STATION:

- 71-00-10 Flexo-Folder-Gluer Bracket
- 95-01-91 Photo Sensor
- 47-01-05 Adhesive Valve, RX Connector

- 30-00-11 Striping Head, Single Bead
 - 30-02-11 Striping Head, 1/4" Pattern
 - 30-04-11 Striping Head, 1/2" Pattern
 - 30-06-11 Striping Head, 3/4" Pattern
 - 30-08-11 Striping Head, 1" Pattern
- (Other pattern sizes available)

TECHNICAL DATA

CONSTRUCTION:

Brass, stainless steel, and aluminum.

SYSTEM LAYOUT

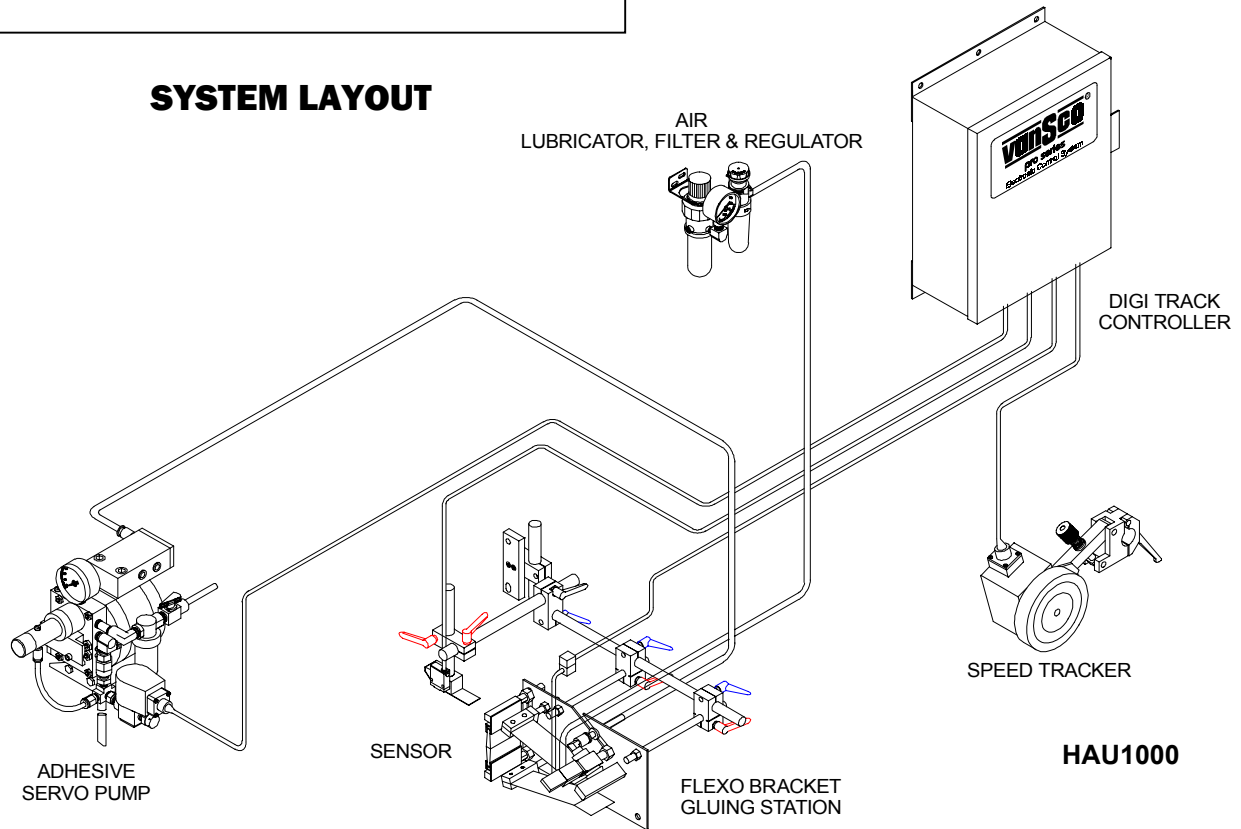

VanSco Products - The Gluing Equipment Innovators

2652 Lashbrook Avenue • South El Monte, CA 91733 • 626-448-7611 • Fax 626-448-0221
E-mail: sales@vansco.com • URL: www.vansco.com

vanSco®

71-00-10

COMPONENT PARTS

Flexo Folder/Gluer Bracket

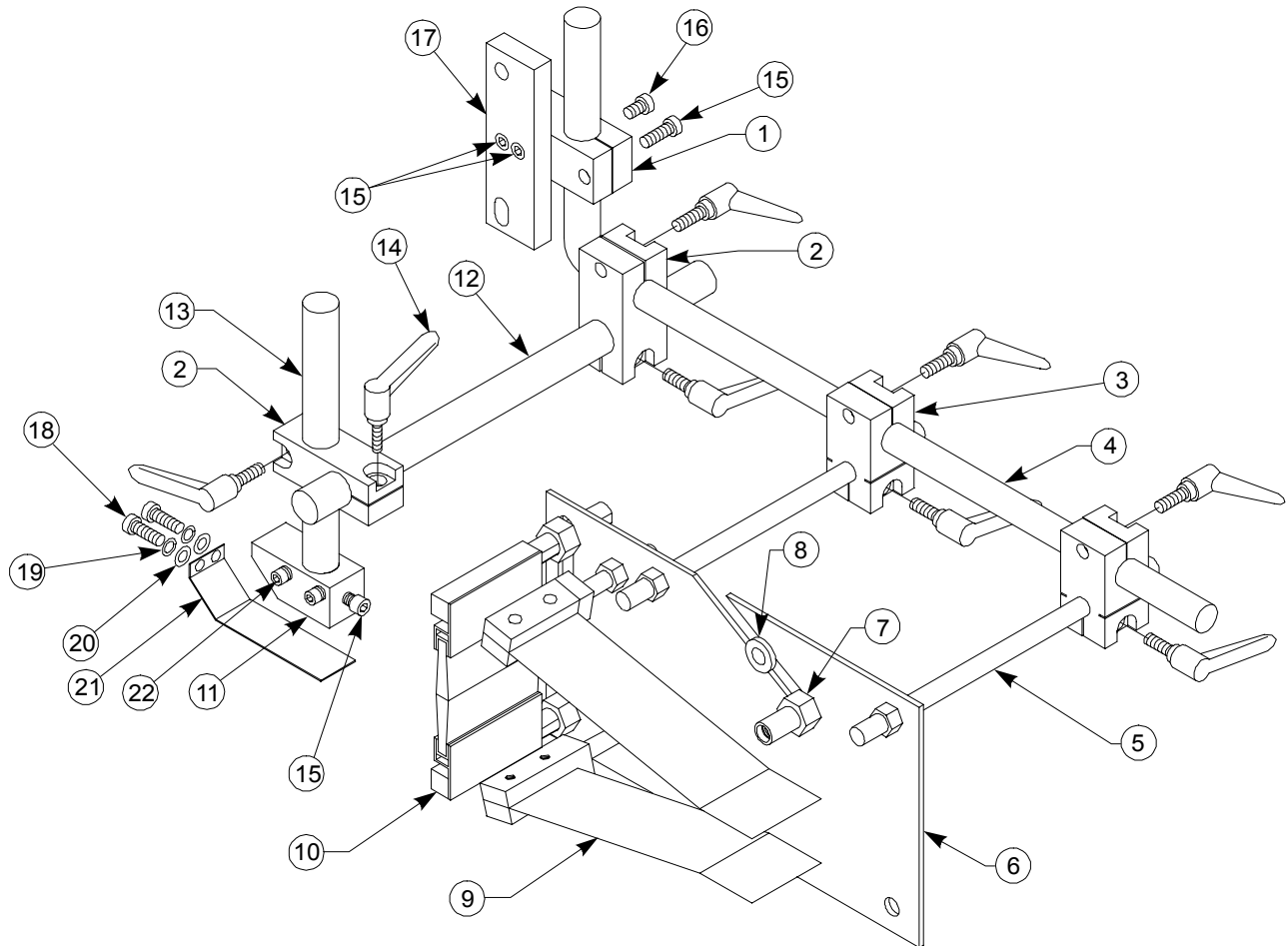

<u>ITEM</u>	<u>PART NO.</u>	<u>QTY</u>	<u>DESCRIPTION</u>
-------------	-----------------	------------	--------------------

1	90-71-47	1	Base Plate
2	79-03-10	2	Cross Connector, 3/4" Dia.
3	79-03-17	2	Cross Connector, 3/4" x 3/8" Dia.
4	90-71-50	1	Mounting Arm, 3/4" Dia.
5	90-71-51	2	Connecting Rod, 3/8" Dia
6	90-71-52	1	Back Plate
7	90-71-53	1	Applicator Mounting Stud
8	90-71-54	1	Teflon Slider Grommet
9	90-71-65	2	Spring Arm Assembly (See over)
10	90-71-62	2	Tab Brush Assembly (See over)
11	90-71-55	1	Photo Sensor Mounting Bracket

<u>ITEM</u>	<u>PART NO.</u>	<u>QTY</u>	<u>DESCRIPTION</u>
-------------	-----------------	------------	--------------------

12	90-71-63	1	Connecting Shaft, 12"
13	90-71-64	1	Connecting Shaft, 6"
14	92-79-09	4	Ratcheting Lever
15	90-06-41	4	1/4-20 x 3/4" SOHD Screw
16	90-02-86	1	1/4-20 x 1/2" SOHD Screw
17	90-71-47	1	Base Plate
18	90-06-59	2	10-32 x 1/2" SOHD Screw
19	90-05-26	4	#10 Split Lock Washer
20	90-05-27	4	#10 Flat Washer
21	90-71-49	1	Spring Steel Arm, 1" Wide
22	90-05-62	2	10-32 x 3/4" SOHD Screw

Distributed By:

HAV0500

VanSco Products - The Gluing Equipment Innovators
2652 Lashbrook Avenue • South El Monte, CA 91733 • 626-448-7611 • Fax 626-448-0221
E-mail: sales@vansco.com • URL: www.vansco.com

vanSco®

71-00-10

COMPONENT PARTS

Flexo Folder/Gluer Bracket

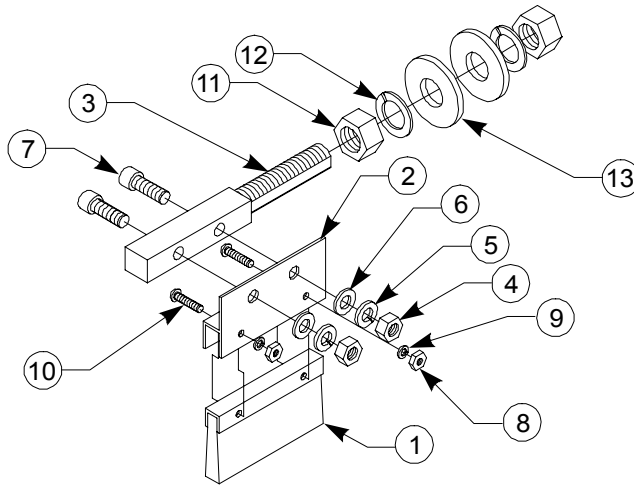

90-71-62

ITEM PART NO. QTY DESCRIPTION

1	90-71-59	1	Tab Brush Bristle
2	90-71-60	1	Tab Brush Holder
3	90-71-61	1	Brush Mounting Bracket
4	90-05-68	2	1/4-20 Hex Nut
5	90-05-28	2	1/4" Split Lock Washer
6	90-07-59	2	1/4" Flat Washer
7	90-06-41	2	1/4-20 x 3/4 SOHD Screw

ITEM PART NO. QTY DESCRIPTION

8	90-06-36	2	6-32 Hex Nut
9	90-06-80	2	#6 Split Lock Washer
10	90-01-10	2	6-32 x 5/8" ROHD Screw
11	90-05-88	2	1/2-20 Hex Nut
12	90-07-69	2	1/2" Split Lock Washer
13	90-03-94	2	1/2" Flat Washer

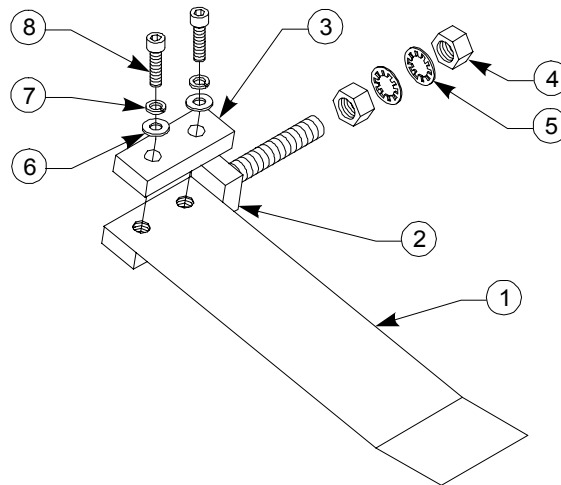

90-71-62

ITEM PART NO. QTY DESCRIPTION

1	90-71-58	1	Spring Steel Arm
2	90-71-56	1	Spring Arm Mounting Base
3	90-71-57	1	Spring Arm Retainer
4	90-05-83	2	3/8-16 Hex Nut

ITEM PART NO. QTY DESCRIPTION

5	90-06-09	2	3/8" Internal Lock Washer
6	90-05-27	2	#10 Flat Washer
7	90-05-26	2	#10 Split Lock Washer
8	90-05-62	2	10-32 x 3/4" SOHD Screw